



Art.Nr.: 74000403 - Vorgelege

- Passend zu den angetriebenen ScaleDRIVE Vorder- und Hinterachsen Art.Nr.: 74000401 und Art.Nr.: 74000400
- wahlweise mit- und ohne Durchtrieb zu montieren.
 - glasfaserverstärktes Kunststoffgehäuse
 - gefräste Zahnräder aus rostfreiem Stahl
 - 4-fach kugelgelagert
 - Übersetzung 5,67 : 1



www.SCALEDRIVE.de



ScaleART OHG - Schillerstraße 3-7 - D67165 Waldsee
Tel.: +49 (0) 6236-416651 - Mail: info@scaleart.de

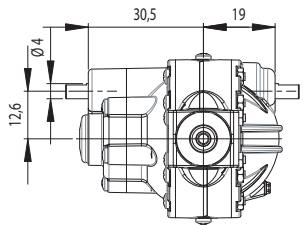

01	Deckel Vorgelege	1	23000251
02	Abschlussdeckel Vorgelege	1	23000252
03	Verschlussdeckel Durchtrieb	1	23000256
04	Antriebsrizzel	1	23000262
05	Ritzelwelle Vorgelege	1	23000266
06	Ritzelwelle Vorgelege mit DT	1	23000265
07	Zahnrad Vorgelege	1	23000264
08	Kugellager D4 x 9 x 4	2	32900002
09	Kugellager D5 x 11 x 4	2	32900005
10	Schraube M2x12	6	32000015
11	Innensechskantschraube M3x4	2	32000604
12	Mutter M2	6	32000002
13	Stift D2x8	2	32000382
14	Passscheibe D4x0,2	2	32000200
15	Fett Tube 10g	1	60000507

Variante 1: Achse ohne Durchtrieb

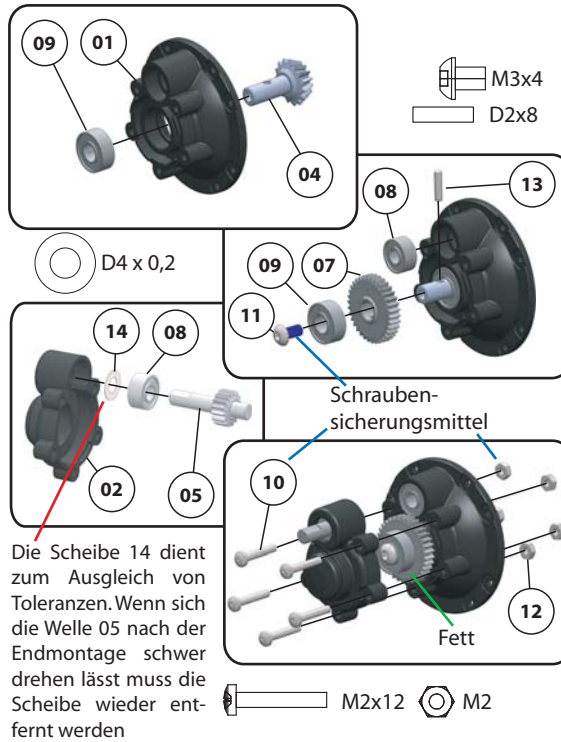

Variante 2: Achse mit Durchtrieb

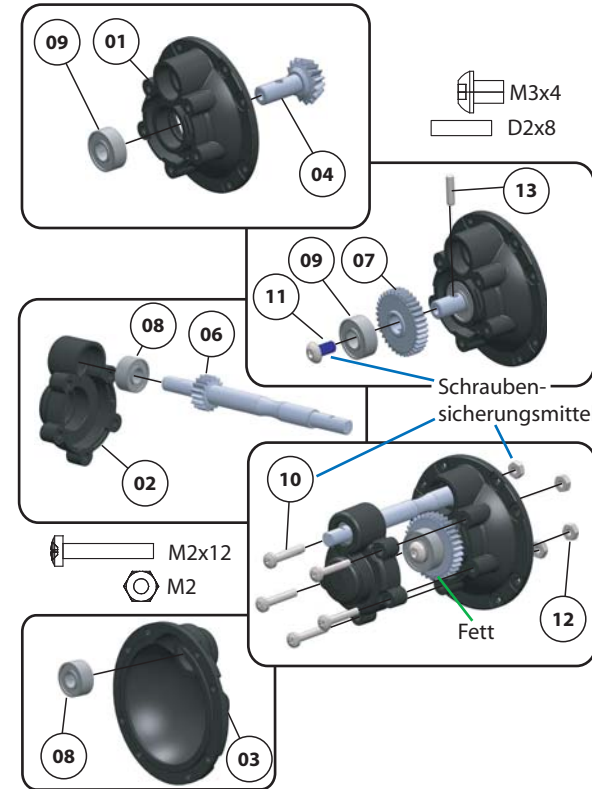

Zur Montage wird das folgende Werkzeug benötigt:

Kreuzschlitzschraubendreher
Steckschlüssel 4,0mm
Innensechskantschlüssel 2mm
Spitzzange
Skalpell
Schraubensicherung mittelfest
kleine Feile

Art.Nr.: 96000007
Art.Nr.: 96000016
Art.Nr.: 96000010
Art.Nr.: 96000051
Art.Nr.: 96000036
Art.Nr.: 60000504

Kardanwelle:

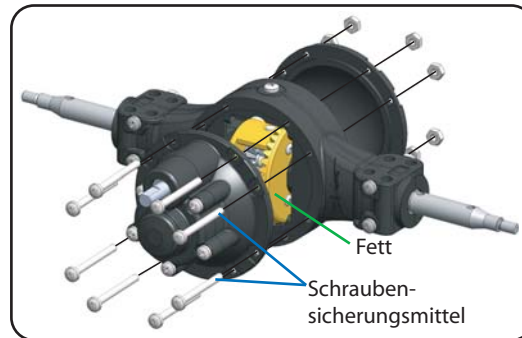
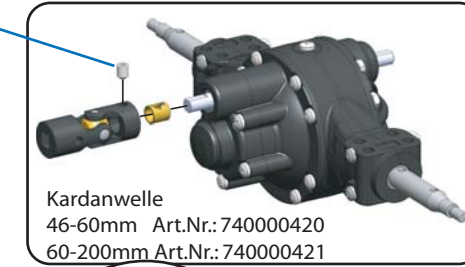

Drücken Sie das Kegelrad **kräftig** nach unten in das Gehäuse, damit das Lager richtig sitzt und das Kegelrad den richtigen Abstand zum Tellerrad erhält!

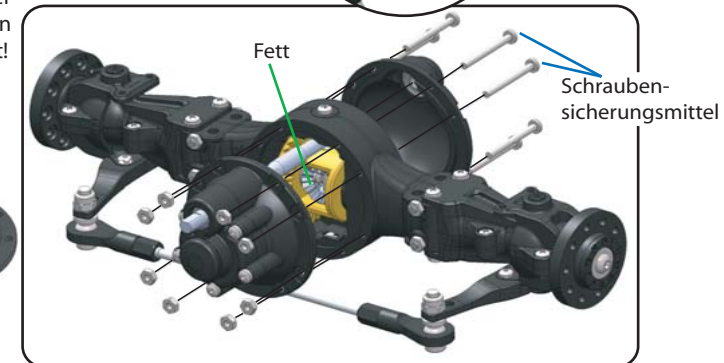

Die Achsen mit Vorgelege verfügen über einen gleichsinnigen Durchtrieb. Das heißt, dass sich die Kardanwelle vor und hinter der Achse immer in dieselbe Richtung dreht. Hierzu ist es auch nötig, dass das Tellerrad in der Achse immer auf derselben Seite montiert wird. Wenn man dies nicht beachtet, drehen später die Antriebsräder gegenläufig und das Fahrzeug blockiert. Die Vorgelege werden immer auf der Seite der Achse montiert, die am nächsten zum Verteilergetriebe gelegen ist.

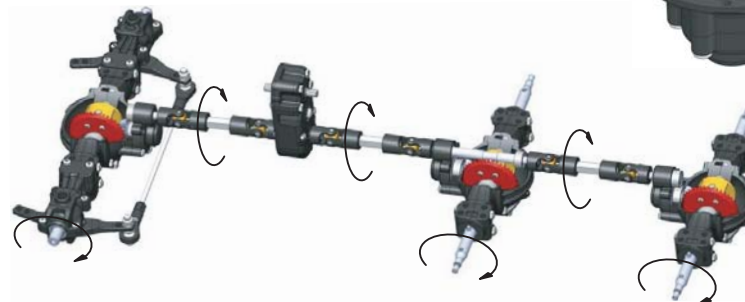



Item nr.: 74000403 - countershaft

- Suitable for the driven Scaledrive front- and rear-axles item nr.: 74000401 and item nr.: 74000400
- mounting with or without 2nd drive is optional
- fibre-glass reinforced plastic
- milled gear made of stainless steel
- 4- ball bearings
- transmission 5,67 : 1



www.SCALEDRIIVE.de



ScaleART OHG - Schillerstraße 3-7 - D67165 Waldsee
Tel.: +49 (0) 6236-416651 - Mail: info@scaleart.de

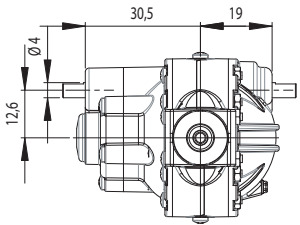

01	cover countershaft	1	23000251
02	endcover countershaft	1	23000252
03	cover 2nd drive	1	23000256
04	drive pinion	1	23000262
05	pinion shaft	1	23000266
06	pinion shaft 2nd drive	1	23000265
07	gear wheel for countershaft	1	23000264
08	ball bearing d4 x 9 x 4	2	32900002
09	ball bearing d5 x 11 x 4	2	32900005
10	screw M2x12	6	32000015
11	allen screw M3x4	2	32000604
12	nut M2	6	32000002
13	pin d2x8	2	32000382
14	adjusting washer d4x0,2	2	32000200
15	grease 10g	1	60000507

Variante 1: Axle without 2nd drive

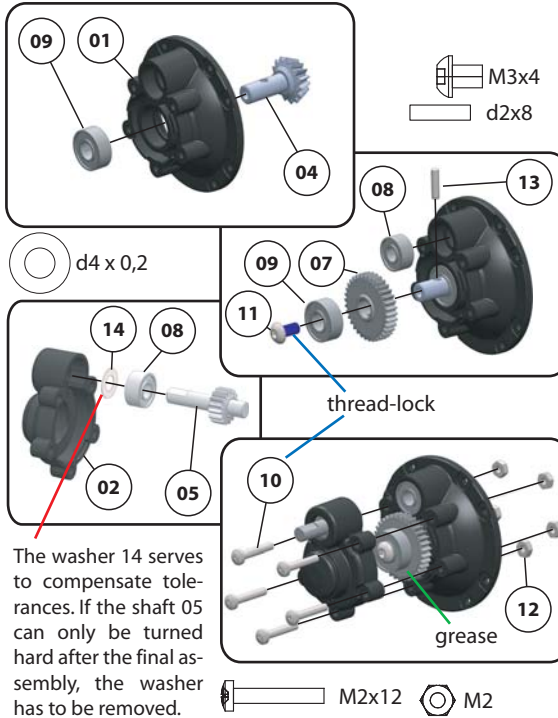

Version 2: Axle with 2nd drive

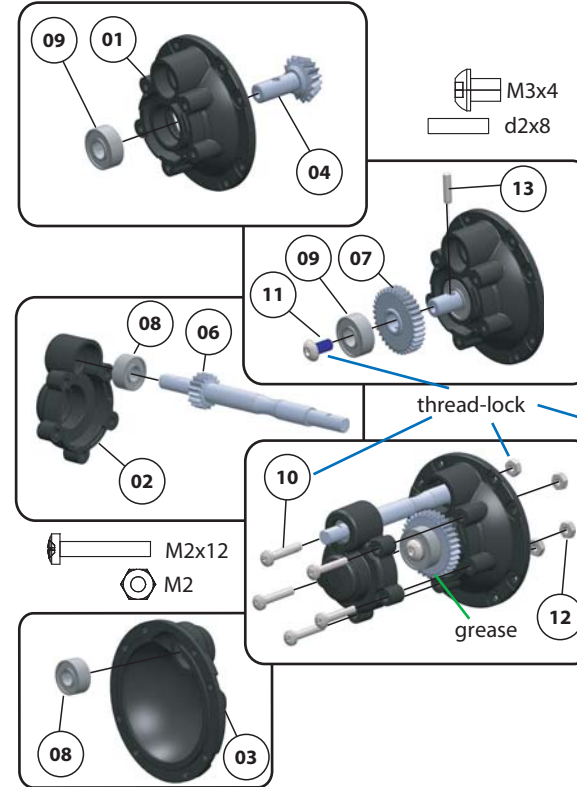

The following tools are required for assembly:

- Phillips screwdriver
- socket wrench 4,0mm
- Allen key 2mm
- nose pliers
- scalpell
- tread locking fluid medium str.
- small file

- Art.Nr.: 96000007
- Art.Nr.: 96000016
- Art.Nr.: 96000010
- Art.Nr.: 96000051
- Art.Nr.: 96000036
- Art.Nr.: 60000504

Drive shaft:



- drive shaft
- 46-60mm item nr.: 740000420
- 60-200mm item nr.: 740000421

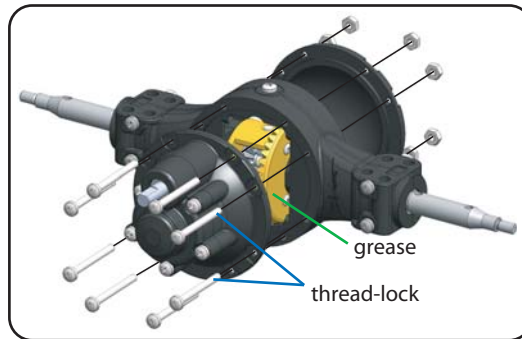
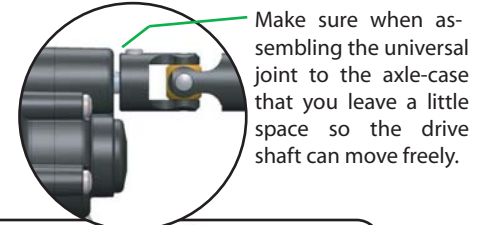

Press the drive pinion **firmly** into the housing, so that the ball bearing is properly seated and the drive pinion has got the correct distance to the crown wheel!

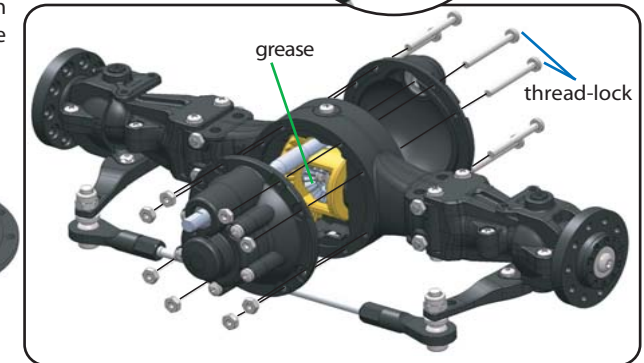

The axles with countershaft have the same drive direction. That means that the drive shaft in front and behind of the axle is always rotating in the same direction. Therefore it is necessary to always mount the crown in the axle to the same sides. If this is not done properly the wheels will then turn into different directions. The vehicle is blocked.
The countershafts will always get mounted to the side of the axle that is closest to the transfer case.

